

Nasarullah Zulfareen, Kulanthi Kannan and Thiruvengadam Venugopal

EFFECT OF METHANOL EXTRACT OF PROSOPIS JULIFLORA ON MILD STEEL CORROSION IN 1M HCL

*Department of Chemistry, Government College of Engineering,
Karuppur Salem-636011, India; fareensha@gmail.com*

Received: July 11, 2015 / Revised: August 18, 2015 / Accepted: November 30, 2015

© Zulfareen N., Kannan K., Venugopal T., 2016

Abstract. The *Prosopis juliflora* extract was investigated as a corrosion inhibitor for mild steel in 1M HCl using weight loss measurements, potentiodynamic polarization, and electrochemical impedance spectroscopy (EIS). The inhibition efficiency of *Prosopis juliflora* increases with an increase in inhibitor concentration and temperature. Polarization studies revealed that *Prosopis juliflora* acts as a mixed type inhibitor for mild steel in 1M HCl. AC impedance indicates that the value of charge transfer resistance increases with the increase in inhibitor concentration. Thermodynamic parameters like activation energy, enthalpy, entropy and free energy were calculated. The surface morphology of *Prosopis juliflora* shows a significant improvement of the mild steel surface.

Keywords: mild steel, acid corrosion, *Prosopis juliflora*, EIS.

1. Introduction

The use of mild steel as a constructional material in industries is more due to their mechanical property, high susceptibility, and low cost. Mostly in acidic industries mild steel is used for desalting, acid pickling, crude oil refining and acidifying. This causes corrosion of material, and materials can be protected by various forms of coating, surface treatment and by adding inhibitors. Inhibitors are electron-rich elements containing N, O, P and S with aromatic rings; they protect the steel from corrosion in acid solutions by adsorbing on the steel surface. But they are not eco-friendly, expensive and have non-renewable sources that influence the corrosion of the equipment. Nowadays natural products are used as corrosion inhibitors because of the non-toxicity, biodegradability and eco-friendliness [4]. The plant extracts are organic in nature, and may be extracted by a

simple procedure with low cost. They have many constituent organic with corrosion inhibiting ability. Plants contain many bioactive constituents like terpenes, alkaloids, flavonoids and phenolic compounds [3]. In the present study corrosion protection is carried out by adding the methanol extract of *Prosopis juliflora*.

Prosopis juliflora is a member of Leguminosae family, which was found in arid and semi-arid regions of India. The methanol extract of *Prosopis juliflora* contains flavonoids, alkaloids, glycosides and ellagic acid, tannin, prosogerin D and procyanidin which have wide applications in pharmacology [2]. This work describes the screening of *Prosopis juliflora* from the methanol extract and its using as a corrosion inhibitor for mild steel in hydrochloric acid.

2. Experimental

2.1. Plant Material

Plant material (seed and skin) of *Prosopis juliflora* was collected from the arid areas of India. The plant material was washed thoroughly with tap water and dried in an oven at 323 K for 48 h. The dried material was beached to form fine powder and filtered through the sieve, then it is stored in the refrigerator at 278 K.

2.2. Preparation of Extract

Prosopis juliflora was extracted with various organic solvents such as methanol, ethanol, hexane, chloroform, acetone and finally with distilled water according to their polarity. 400 g of the dried plant material were taken in a round-bottomed flask, and methanol was added until the plant material was fully immersed in the solvent. The whole setup was kept for 8 h under constant shaking. The entire process was repeated

two-three times until the supernatant was collected and pooled together. After filtration the plant material was dried completely to evaporate the hexane. Finally, the extract was concentrated in a rotary evaporator at 327 K and it was kept in the air tight bottle at 278 K [1].

2.3. Specimen Preparation

The composition of mild steel used in this work was (wt %): Fe 99.75; Mn 0.01; Cu 0.01; Si 0.02; P 0.02 and C 0.18. The specimens of dimension 5×1.5 cm were used. The specimens were polished using 1/0, 2/0, 3/0 and 4/0 grade emery papers and pickling solution were used to wash the mild steel till the metal became clear. Then they were washed with distilled water, acetone and kept in oven for immediate usage.

2.4. Weight Loss Method

Mild steel, which enhances the corrosion rate in industries, is used in this work. By adding the *Prosopis juliflora* methanol extract, the inhibition efficiency of mild steel increases with an increase in concentration and temperature that minimizes the corrosion rate. Weight loss methods were carried out by weighing the specimens before and after immersion in 1M HCl in the absence and presence of the inhibitor. From the initial and final mass of the specimen, the weight loss was calculated. From this weight loss value, the inhibition efficiency (*I.E.*) and corrosion rate were determined.

$$I.E.or h = q \cdot 100 \% \quad (1)$$

where q (surface coverage) = $\frac{\Delta W_u - \Delta W_i}{\Delta W_u}$; ΔW_u and ΔW_i – metal weight losses (g) in the absence and presence of the inhibitor, respectively.

2.5. Electrochemical Studies

The surface of the electrode was prepared by taking mild steel specimen of 1 cm and embedded with Teflon coating. The coated mild steel was polished with 1/0, 2/0, 3/0 and 4/0 grade emery papers and degreased with acetone before usage.

2.6. Electrode Cell Assembly

Electrochemical Workstation Model 600 D/E Series was used for polarization and AC impedance studies. Three electrode systems were used for this purpose, platinum electrode was an auxiliary electrode, saturated calomel electrode (SCE) was a reference electrode and mild steel by size of 1 cm was used as a working electrode.

2.7. Procedure and Calculation

Studies concerning electrochemical workstation polarization and AC impedance were carried out in the

presence and absence of the inhibitor. The percentage of inhibition efficiency and the degree of surface coverage θ were calculated [6].

$$I.E.or h = \left(1 - \frac{i'_{corr}}{i_{corr}}\right) \cdot 100 \% \quad (2)$$

where i'_{corr} and i_{corr} are the corrosion current densities of mild steel in the absence and presence of the inhibitor, respectively.

The corrosion rate (mmpy) is calculated according to Eq. (3):

$$CR = \frac{87.65 \Delta W}{A \cdot t \cdot D} \quad (3)$$

where ΔW is weight loss of metal, g; A is the area of specimen, cm; t is time, h and D is the density of metal, m.

$$Cdl = \frac{1}{2 \cdot 3.14 \cdot f_{max} \cdot Rct} \quad (4)$$

where Cdl – double layer capacitance, F; f_{max} – the frequency, Hz and Rct – charge transfer resistance, Ω .

2.8. Surface Analysis

The methanol extract of *Prosopis juliflora* was characterized by SEM and FT-IR (Lambda FT-IR-7600).

3. Results and Discussion

3.1. Screening Method

Prosopis juliflora extract was subjected to phytochemical screening for the presence of alkaloids, flavonoids, terpenes, tannin, saponin and phenolic compounds. The results are represented in Table 1.

3.2. Weight Loss Method

The inhibition efficiency of methanol extract of *Prosopis juliflora* increases with the increase in concentration and temperature. This is due to the blocking effect of methanol extract of *Prosopis juliflora* on the metal surface *via* adsorption and film formation mechanism [5]. The maximum inhibition efficiency of *Prosopis juliflora* at 303 K was found to be 64.52 % at the inhibitor concentration of 700 ppm. As the temperature increases from 303 to 333 K, the efficiency of methanol extract of *Prosopis juliflora* also increases and the inhibition efficiency was found to be 83.72 % at the same concentration. In Table 2 inhibition efficiency, surface coverage and corrosion rate of methanol extract of *Prosopis juliflora* are shown. As the concentration of the inhibitor increases, the rate of corrosion is minimized that indicates the methanol extract of *Prosopis juliflora* acts as a good inhibitor for mild steel in 1M HCl.

Table 1

Phytochemicals present in the extract obtained from the seed and skin of *Prosopis juliflora*

Phytochemicals	Results
Alkaloids	+
Flavonoids	+
Tannin	+
Phenol	+
Saponin	–
Amino acids	–
Terpenoids	+
Steroids	+
Carbohydrate	+

Table 2

Weight loss measurements of methanol extract of *Prosopis juliflora* within 303–333 K

Temperature, K	Inhibitor concentration, ppm	Corrosion rate, mmpy	Surface coverage θ	Inhibition efficiency <i>I.E.</i> , %
303	Blank	15.30	–	–
	100	4.35	0.5116	51.16
	200	3.86	0.5634	56.34
	300	3.02	0.5785	57.85
	400	2.88	0.5811	58.11
	500	2.52	0.6018	60.18
	600	2.28	0.6277	62.77
	700	2.01	0.6452	64.52
313	Blank	35.94	–	–
	100	7.75	0.5987	59.87
	200	5.17	0.6166	61.66
	300	4.53	0.6217	62.17
	400	3.66	0.6383	63.83
	500	3.37	0.6518	65.18
	600	2.93	0.6797	67.97
	700	2.77	0.6801	68.01
323	Blank	72.16	–	–
	100	19.46	0.6248	62.48
	200	18.09	0.6696	66.96
	300	17.61	0.6844	68.44
	400	15.45	0.7012	70.12
	500	14.86	0.7188	71.88
	600	12.48	0.7347	73.47
	700	11.17	0.7488	74.88
333	Blank	118.60	–	–
	100	30.64	0.6931	69.31
	200	28.58	0.7217	72.17
	300	24.75	0.7399	73.99
	400	23.11	0.7574	75.74
	500	21.57	0.7965	79.65
	600	20.71	0.8277	82.77
	700	18.67	0.8372	83.72

3.3. Potentiodynamic Polarisation Studies

As the concentration of methanol extract of *Prosopis juliflora* increases, the inhibition efficiency also increases with the decrease in the corrosion rate. Corrosion parameters such as corrosion potential, anodic tafel slope and cathodic tafel slope, corrosion current, and inhibition efficiency were calculated. It implies that, the addition of the inhibitor shifts the anodic polarization to more positive and cathodic to more negative values. It indicates that the addition of methanol extract of *Prosopis juliflora* reduces the anodic dissolution and the added methanol extract of *Prosopis juliflora* acts as a mixed type inhibitor [7].

In Table 3, the i_{corr} values decrease with the increase in the inhibitor concentration (100–700 ppm) with a shift of E_{corr} (corrosion current) to a more negative potential. This indicates that the methanol extract of *Prosopis juliflora* suppresses cathodic reaction predominantly than the anodic process. The maximum inhibition efficiency of the methanol extract of *Prosopis juliflora* was found to be 85.94 % at 700 ppm at 333 K. The inhibition efficiency of the methanol extract of *Prosopis juliflora* is in a good agreement with the value obtained by the weight loss method. Polarization curves of methanol extract of *Prosopis juliflora* in 1M HCl at 333 K is shown in Fig. 1.

3.4. AC Impedance Study

The open circuit potential for mild steel in 1M HCl in the presence and absence of the inhibitor is shown in Fig. 2. Impedance parameters derived from Nyquist plots are given in Table 4. It is observed from the table that the value of charge transfer resistance (R_{ct}) increases with an

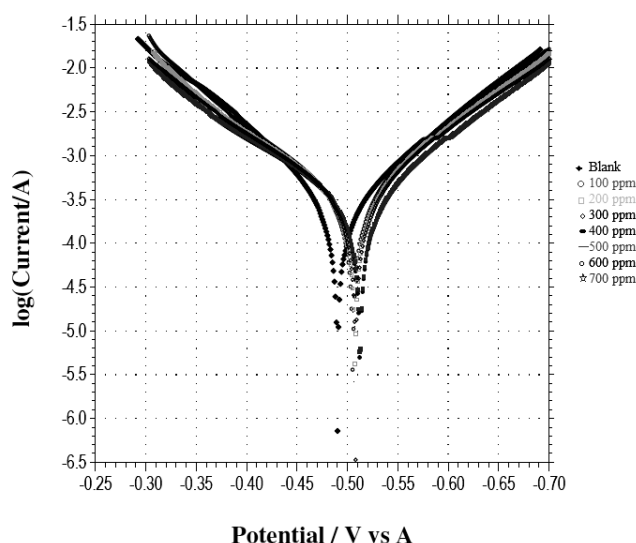

Fig. 1. Polarization curves of mild steel in 1M HCl in the absence and presence of the inhibitor at 333 K

increase in the inhibitor concentration but the value of double layer capacitance (Cdl) decreases with the increase in the inhibitor concentration. The inhibition efficiency increases with the increase in inhibitor concentration. The maximum inhibition efficiency of methanol extract of *Prosopis juliflora* was found to be 87.75 % at 700 ppm at 333 K. The impedance diagram has almost semicircular appearance due to the electrical double layer and charge transfer resistance, which indicates that the corrosion of mild steel is mainly controlled by the addition of the inhibitor [8]. The inhibition efficiency obtained using AC impedance method is in good agreement with the inhibition efficiency obtained using weight loss and polarization method.

A simple Randle's equivalent circuit was fixed to fit the mechanism of the inhibitor with the charge transfer resistance (R_{ct}), double layer capacitance ($Cdl1$), ($Cdl2$), and solution resistance (R_s) was shown in Fig. 3.

3.5. Temperature Effect

Temperature has a diverse effect on the corrosion of mild steel in an acid medium. With the increase in temperature the corrosion may increase due to the higher action of the solvent without the inhibitor. With the addition of the inhibitor, the inhibition efficiency may increase or decrease depending on the inhibitor used. The rate of corrosion increases with the increase in temperature for all solutions. The temperature effect on the corrosion inhibition of the plant extract may be multifaceted with many changes due to etching of the metal, and chemisorption of the inhibitor. There may be also decomposition of inhibitor, rearrangement of the inhibitor or rapid desorption of the inhibitor on the metal surface [9].

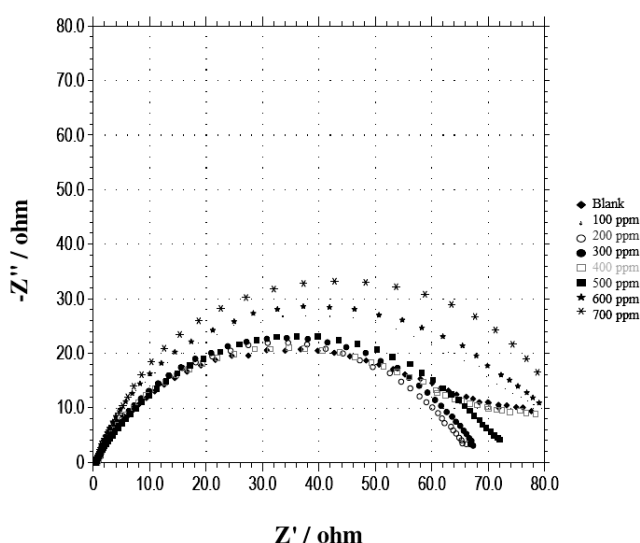

Fig. 2. AC impedance curves of mild steel in 1M HCl in the absence and presence of the inhibitor at 333 K

Table 3

Tafel polarization parameters for mild steel in 1M HCl with *Prosopis juliflora* within 303–333 K

Temperature, K	Inhibitor concentration, ppm	E_{corr} , V/SCE	$-b_a$, mV dec ⁻¹	$-b_c$, mV dec ⁻¹	i_{corr} , mA cm ⁻²	CR, mmpy	I.E., %
303	Blank	-0.424	6.78	9.17	3.649	15.30	–
	100	-0.518	10.63	8.10	2.148	4.35	41.13
	200	-0.531	10.39	8.15	2.016	3.86	44.75
	300	-0.537	11.37	7.66	1.957	3.02	46.36
	400	-0.538	11.09	7.13	1.855	2.88	49.16
	500	-0.552	11.69	6.48	1.638	2.52	55.11
	600	-0.581	12.17	6.77	1.557	2.28	57.33
	700	-0.579	13.67	6.47	1.497	2.01	58.97
313	Blank	-0.418	5.36	7.56	5.215	35.94	–
	100	-0.420	13.41	6.95	2.971	7.75	43.02
	200	-0.431	13.68	6.68	2.819	5.17	45.94
	300	-0.438	12.39	6.11	2.673	4.53	48.74
	400	-0.449	14.18	5.90	2.527	3.66	51.54
	500	-0.457	15.66	5.84	2.115	3.37	59.44
	600	-0.462	16.87	4.73	2.012	2.93	61.41
	700	-0.475	17.88	4.02	1.697	2.77	67.45
323	Blank	-0.489	8.31	6.33	7.185	72.16	–
	100	-0.496	19.37	5.58	3.572	19.46	50.28
	200	-0.457	20.22	5.19	3.452	18.09	51.95
	300	-0.466	24.21	5.03	3.176	17.61	55.79
	400	-0.466	26.68	4.99	3.051	15.45	57.36
	500	-0.467	32.36	4.75	2.973	14.86	58.62
	600	-0.472	35.57	4.79	2.736	12.48	61.92
	700	-0.478	38.71	4.88	2.174	11.17	69.74
333	Blank	-0.514	19.73	5.78	9.843	118.60	–
	100	-0.517	36.97	5.55	4.317	30.64	56.14
	200	-0.577	38.58	5.20	3.784	28.58	61.55
	300	-0.570	40.41	5.09	3.007	24.75	69.45
	400	-0.587	42.77	4.57	2.273	23.11	76.90
	500	-0.590	44.76	4.89	1.951	21.57	80.17
	600	-0.592	48.78	4.11	1.733	20.71	82.39
	700	-0.598	49.55	3.95	1.383	18.67	85.94

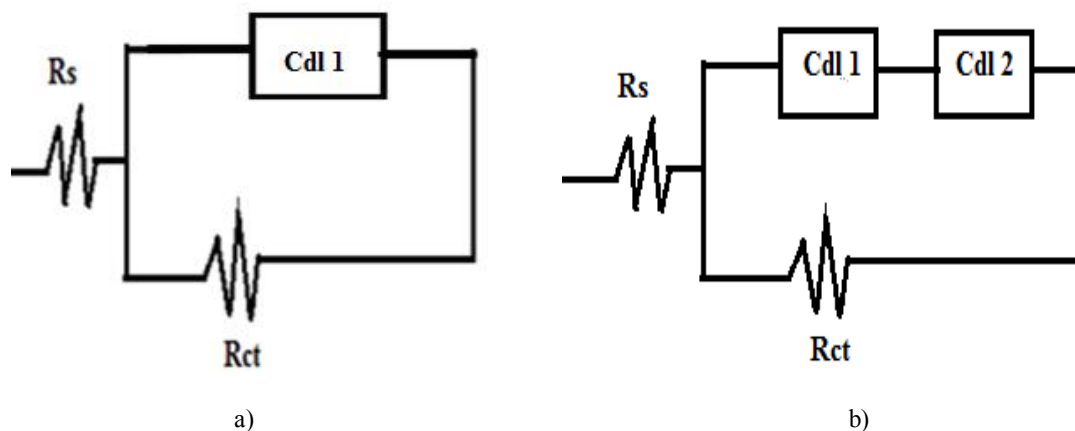

Fig. 3. Equivalent circuit for mild steel in 1M HCl in the absence (a) and presence of inhibitor (b) at 333 K

Table 4

AC Impedance parameters for mild steel in 1M HCl with/without Prosopis juliflora

Temperature, K	Inhibitor concentration, ppm	R_{ct} , Ω	C_{dl} , F	$I.E.$, %
303	Blank	22.14	559	–
	100	39.61	90.19	44.10
	200	41.36	88.47	46.47
	300	43.87	76.14	49.53
	400	46.77	70.21	52.66
	500	48.12	64.75	53.99
	600	51.68	58.96	57.15
	700	52.73	42.35	58.01
313	Blank	19.66	1250	–
	100	40.15	775.1	51.03
	200	43.68	789.2	54.99
	300	45.39	796.8	56.68
	400	49.11	804.2	59.96
	500	53.88	832.3	63.51
	600	55.57	847.5	64.62
	700	58.36	815.7	66.31
323	Blank	11.80	1569	–
	100	41.95	854.7	71.87
	200	42.65	852.5	72.33
	300	43.81	846.8	74.13
	400	46.85	822.9	74.81
	500	48.14	815.6	75.48
	600	50.64	891.4	76.69
	700	52.17	895.5	77.38
333	Blank	8.37	1875	–
	100	42.19	974.5	80.16
	200	43.57	932.8	80.78
	300	49.90	913.7	83.22
	400	53.19	897.4	84.63
	500	57.11	871.1	85.34
	600	60.32	860.3	86.12
	700	68.34	853.9	87.75

Table 5

Activation parameters of corrosion of mild steel in 1M HCl solution in the absence and the presence of the inhibitor

Concentration, ppm	E_a , kJ/mol	$A \cdot 10^9$, A/cm ²	ΔH° , kJ/mol	ΔS° , J/K·mol	ΔG° , kJ/mol			
					303	313	323	333
Blank	57.54	135	-25.03	-130.50	14.51	15.82	17.12	18.43
100	56.89	27	-16.52	-155.00	30.45	31.99	33.55	35.09
300	64.32	332	-9.80	-154.00	36.86	38.4	39.94	41.5
500	66.38	599	-4.96	-145.00	38.97	45.38	41.87	43.32
700	67.65	777	-2.24	-165.00	47.75	49.40	51.1	52.70

Corrosion rate normally increases with the increase in temperature, which may lead to the decrease in inhibition efficiency. But when a chemisorption takes place between the inhibitor and mild steel, the inhibition efficiency increases with the increase in temperature. There is an equilibrium between the inhibitor and mild steel at any temperature. When the temperature is

changed, the equilibrium shifts, and the new equilibrium occurs. Arrhenius equation and transition state equation are used for the calculation of the activation energy, enthalpy of adsorption and entropy of adsorption.

$$\log(CR) = \frac{-E_a}{2.303RT} + \log A \quad (5)$$

$$CR = \frac{RT}{Nh} \exp \frac{\Delta S^*}{R} \exp \frac{-\Delta H^*}{RT} \quad (6)$$

where CR is the corrosion rate, R is the universal gas constant, T is the absolute temperature, N is the Avogadro number, h is the Plank's constant, ΔS^* is the entropy change for the adsorption process and ΔH^* is the enthalpy change.

The plot of $\log(CR)$ vs. $1000/T$ for blank and various concentrations of inhibitor are shown in Fig. 4 and a straight line was obtained. E_a is calculated from the slope of the line, and the results are tabulated in Table 5. The value of E_a decreases with the increase in temperature. The plot (Fig. 4) indicates the physical adsorption is a dominant process. It is evident from higher E_a value at higher temperature and also from the decrease in the ΔH^* values with the increase in temperature.

3.6. Adsorption Isotherm

Surface coverage θ is used in this work to derive much important informations about the corrosion inhibition of the methanol extract of the *Prosopis Juliflora* seeds. Surface coverage gives important concept that controls the corrosion inhibition mechanism of the extract on the mild steel. Tafel polarization method is employed in this work to find the surface coverage θ at different inhibitor concentration. Surface coverage can be calculated from the following equation.

$$q = \frac{u_0 - u}{u} \quad (8)$$

where u_0 and u are the corrosion rates without and with the inhibitor, respectively.

The value of the surface coverage is considered as the important information from which various isotherms can be plotted, and the best one was found out. Langmuir, Freundlich, Temkin, Hill de Boer, Flory-Huggins, Frumkin, Dhar-Flory Huggins, Parsons and Bockris Swinkles isotherms are most frequently used for determination of adsorption studies according to the general formula:

$$f(q, x) e^{(-2aq)} = K \cdot C \quad (9)$$

where $f(\theta, x)$ is the configurational factor, θ is the surface coverage, K is the constant of the adsorption process and can be equated to equilibrium constant; C is the inhibitors concentration, g/l; a is the molecular interaction parameter (1, 2) of all the isotherm tested. Langmuir isotherm showed the best fit for the data correlation coefficient with values greater than 0.97. The model of Langmuir isotherm equation is:

$$\frac{C}{q} = \frac{1}{K} + C \quad (10)$$

The slope of the line obtained from the adsorption isotherm was found to be more than 1 (Table 6), which indicates that some constituents of the *Prosopis juliflora* extract may occupy more than one adsorption site in the mild steel. This can be attributed to various functional groups (like $-\text{COOH}$, $-\text{NH}_2$) present in the extract, which has more than one coordination number.

Fig. 5 shows the plot of C/θ vs. C for different temperatures and the values of R^2 and slope are listed in Table 6. The adsorption process is based on three assumptions: (i) there may be a monolayer adsorption and it cannot proceed beyond monolayer; (ii) all the adsorption sites are equal denoting the probability of adsorption is the same; (iii) there is no interaction between the adsorbing molecules and the adsorption process. The resulting value of the slope and correlation co-efficient suggest that there is a monolayer adsorption between the mild steel and extract molecules.

$$\Delta G_{ads}^0 = -RT(\ln 55.5 K_{ads}) \quad (11)$$

By using Eq. 11 the free energy is calculated. ΔG_{ads}^0 ranges from -18.1 to -21.0 kJ/mol. The high value of K_{ads} and the negative sign of ΔG_{ads}^0 indicate that spontaneous the adsorption takes place. Normally the value of ΔG_{ads}^0 of above -20 kJ/mol indicates that the main process is physisorption due to the van der Waals attraction between the mild steel and extract molecules, but when the value of ΔG_{ads}^0 becomes -30 kJ/mol or more negative, then chemisorption is a dominate process. It is inferred from Table 6 that there is no correlation between the temperature and ΔG_{ads}^0 and the values remain fairly constant around -20 kJ/mol that indicates that there is a physical adsorption between the extract molecules and the mild steel and chemisorption does not occur even at high temperature [10].

3.7 Surface Analysis

The peak at 1268cm^{-1} corresponding to CH_2 group is observed in Fig. 6. The peak at 1695cm^{-1} corresponds to the carbonyl group, and peak at 1600.5cm^{-1} indicates the presence of NH. A broad peak in the region of 3732cm^{-1} indicates the presence of OH group.

The methanol extract of *Prosopis juliflora* was characterized by SEM. The SEM images of mild steel and inhibitor are shown in Fig. 7. The SEM images clearly differentiate the formation of the protective layer on the surface of the mild steel.

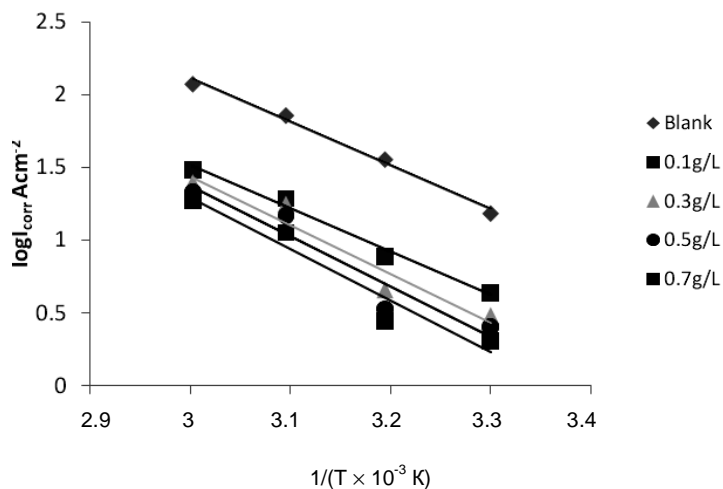

Fig. 4. Plot of $\log(i_{corr})$ vs. $1/T$ for the methanol extract of Prosopis Juliflora

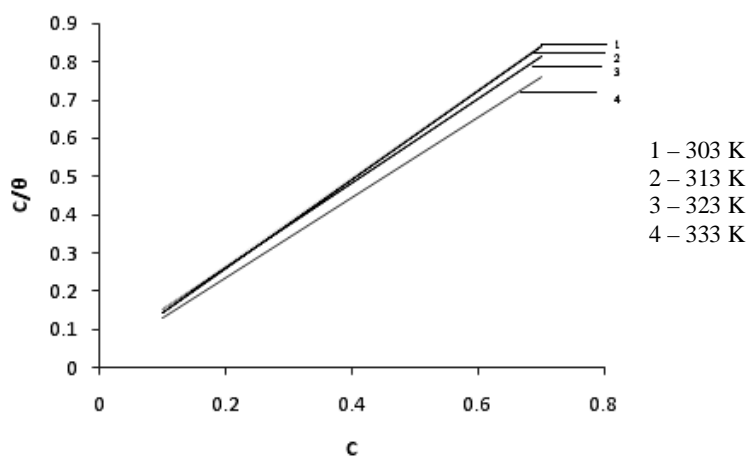

Fig. 5. Plot of C/θ vs. C for different temperatures of methanol extract of Prosopis juliflora

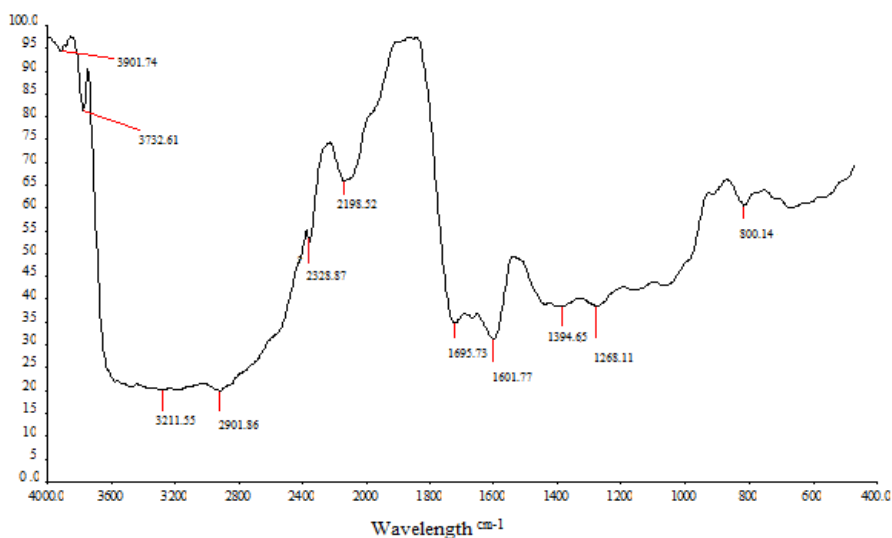

Fig. 6. FT-IR spectrum of methanol extract of Prosopis juliflora

Table 6

Equilibrium, statistical and thermodynamic parameters for adsorption of methanol extract on mild steel surface in 1M HCl

Temperature, K	R^2	K_{ads}	Slope	ΔG , kJ/mol
303	0.998	24.57	1.106	-18.1601
313	0.999	40.58	1.050	-20.0652
323	0.997	25.99	1.151	-19.5097
333	0.999	35.65	1.160	-20.9887

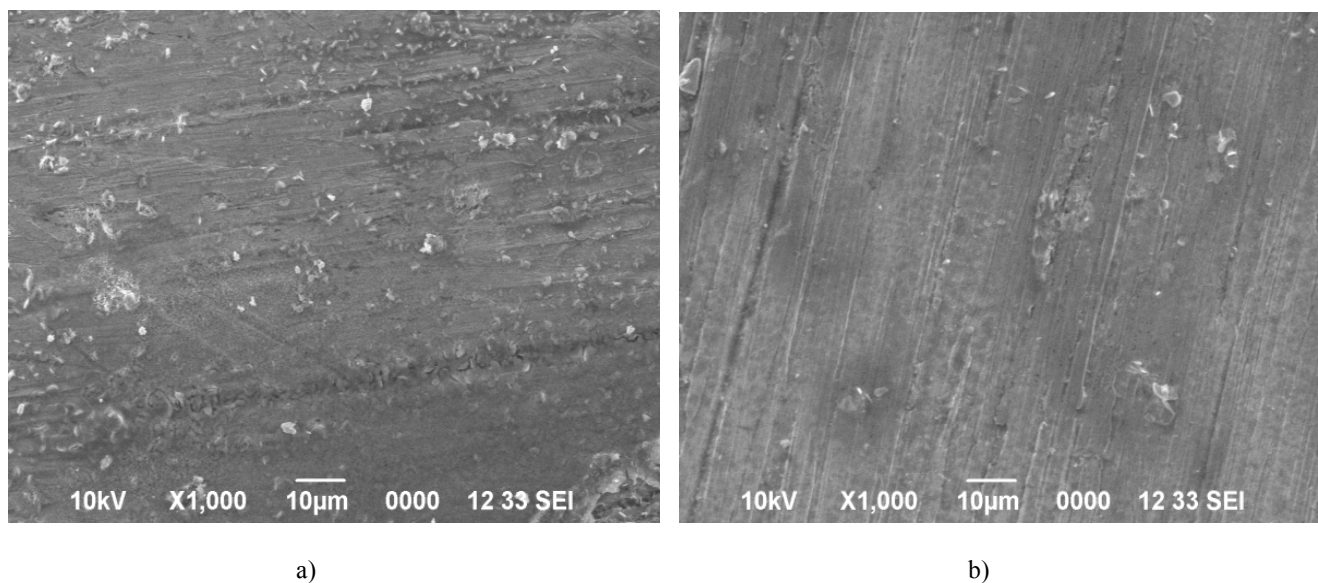

Fig. 7. SEM images of mild steel in 1M HCl in the absence and presence of the inhibitor

4. Conclusions

The inhibition efficiency of methanol extract of *Prosopis juliflora* increases with the increase in concentration and temperature. The inhibition efficiency of methanol extract of *Prosopis juliflora* obtained through AC impedance techniques was found to be in good agreement compared with weight loss and polarization method. The methanol extract of *Prosopis juliflora* acts as a mixed type inhibitor because it controls both hydrogen evolution mechanism and metal dissolution process. FT-IR peak confirms the presence of *Prosopis juliflora* at a particular region. The adsorption of methanol extract of *Prosopis juliflora* obeys Langmuir adsorption isotherm.

References

- [1] Singh S.: IJCPR, 2012, **4**, 3.
- [2] dos Santos E., Pereira M., da Silva C. *et al.*: Int. J. Mol. Sci, 2013, **14**, 8496.
- [3] Getachew S., Demissew S. and Woldemariam T.: Arab. J. Chem, 2012, **3**, 105.
- [4] Kamal C. and Sethuraman M.: Arab. J. Chem, 2012, **5**, 155.
- [5] Znini L., Majidi A., Bouyanzer P. *et al.*: Arab. J. Chem., 2012, **5**, 467.
- [6] Uwah I., Okafor P. and Ebieke V.: Arab. J. Chem, 2013, **6**, 285.
- [7] Hazwan Hussin M., Jain Kassim M., Razali N. *et al.*: Arab. J. Chem, 2011. doi:10.1016/j.arabjc.2011.07.002.
- [8] Al-Otaibi M., Al-Mayouf A., Khan M. *et al.*: Arab. J. Chem, 2014, **7**, 340.

- [9] Saliyan R. and Adhikari V.: Ind. J. Chem. Technol., 2009, **16**, 162.
[10] Hamdy Hassan H., Abdelghani E. and Amin M.: Electrochim. Acta, 2007, **52**, 6359.
[11] Patel N., Jauhariand S., Mehata G. et al.: Int. J. Electrochem. Sci., 2013, **8**, 2635.

**ВПЛИВ МЕТАНОЛЬНОГО ЕКСТРАКТУ
PROSOPIS JULIFLORA НА КОРОЗІЮ
НИЗЬКОВУГЛЕЦЕВОЇ СТАЛІ В 1 М НСІ**

Анотація. Досліджено екстракт *Prosopis juliflora* як інгібітора корозії низьковуглецевої сталі в 1М НСІ, з викорис-

танням методу вимірювання втрати маси, потенціодинамічної поляризації та електрохімічної імпедансної спектроскопії (EIS). Показано, що інгібуюча здатність *Prosopis juliflora* зростає із збільшенням концентрації інгібітора й температури. Внаслідок поляризаційних досліджень визначено, що *Prosopis juliflora* діє як інгібітор змішаного типу для низьковуглецевої сталі в 1 М НСІ. За допомогою EIS визначено, що опір перенесення заряду зростає зі збільшенням концентрації інгібітору. Розраховані такі термодинамічні параметри, як енергія активації, ентальпія, ентропія і вільна енергія.

Ключові слова: низьковуглецева сталь, кислотна корозія, *Prosopis juliflora*, електрохімічна імпедансна спектроскопія.